

BOLT MINI

HIGH PERFORMING DMX WORK LIGHT
FOR THEATRICAL APPLICATIONS

Housing

200W : 8.26" x 11.41" x 9.05" | 15 lbs

Material

Housing : High Pressure Die-Cast Aluminum
Lens : Tempered Glass

Power Input

200W | 120V, 120-277V

Lumen Output

White : 14,660 lm (100W)
Royal Blue : 1,210 lm (100W)

Dimming

Standard 1-10V : Dims to 10%
DMX : High resolution dims to 10%

Color Quality

CRI 75, CRI 85

Rated Life

> 100,000 Hours (L70)

Finish



Black

Color Temperature



3000K



3500K



4000K



5000K

+



Royal Blue

Optics



30°



60°



Wide

Mounting



Bracket

Warranty

5 year limited warranty

Listing



SPECIFICATION SHEET DUAL COLOR DMX WORK LIGHT

Theatrical DMX Work Light

The Bolt Mini is a compact yet powerful DMX-compatible work light, now available in a dual-color configuration with independently controlled white and royal blue channels—ideal for backstage applications where minimal visual interference is critical. Compatible with 0-10V, Forward or Reverse Phase, and 8-bit DMX dimming controls. Offered with a range of beam spreads, theatrical mounting options such as a C-Clamp, and a choice of hard-wired or PowerCON True1 power connections.



SPECIFICATION

PROJECT NAME

DATE

CATALOG #

QUANTITY

The product configurator function on this page works only with the latest version of Chrome or Adobe Acrobat Reader.

<input type="text" value="BLTM"/>	MODEL	BOLT MINI SERIES		
<input type="text" value="200"/>	WATTAGE	200 200W (White : 100W, Royal Blue : 100W)		
<input type="text"/>	CCT / CRI	308B 3000K(CRI 85) + Royal Blue 507B 5000K(CRI 75) + Royal Blue	358B 3500K(CRI 85) + Royal Blue	408B 4000K(CRI 85) + Royal Blue
<input type="text"/>	VOLTAGE	120 120V	UNV 120 – 277V	
<input type="text"/>	DIMMING	STV Standard 1-10V dims to 10% DMXP DMX dims to 10% (Phoenix Connector)	DMX DMX dims to 10% (XLR Sockets)	DMXR DMX dims to 10% (RJ45 Sockets)
<input type="text"/>	BEAM ANGLE	30 30°	60 60°	WD¹ Wide
<input type="text" value="BLK"/>	FINISH	BLK Black		
<input type="text" value="BRK"/>	MOUNTING	BRK Bracket		
<input type="text"/>	POWER	HW² Hard Wired	TRU1 PowerCON True1 Outlet	
<input type="text"/>	ACCESSORIES	WG³ Wire Guard (IK10 Rating) DF⁶ Diffuser	GSB⁴ Glare Shield Baffle CLP C-clamp Mount	GSV⁵ Glare Shield Visor

CLEAR FORM

¹ Please factor in change in lumen output of -20%
² Include 2ft Whip and bare conductor ends
³ Please factor in change in lumen output of -14%
⁴ Please factor in change in lumen output of -40%
⁵ Please factor in change in lumen output of -25%
⁶ Please factor in change in lumen output with Diffuser (-20% with WD; -12% with other degrees)

TECHNICAL DETAILS

Electrical

- White : 14,660 lm (100W)
- Royal Blue : 1,210 lm (100W)
- Power Input : 120V, Universal (120-277V)
- Operating Temperature : -40°F~104°F
- Surge Protection : Built-in is 4KV

LED Features

- Color Temperature : 3000K, 3500K, 4000K, 5000K + Royal Blue
- CRI 75, CRI 85
- Long lasting LED luminaire tested under TM21 lumen maintenance L70 @ 100,000 Hrs

Optics

- Precision molded high transmittance clear PC lens
- Beam Angle : 30°, 60°, WD

Advanced Dimming

- Proprietary VX Driver™ is incorporated to all dimming options for video flicker-free lighting
- Standard 1-10V : Dims to 10%
- DMX : Dims to 10% (XLR)
- DMXR : Dims to 10% (RJ45)
- DMXP : Dims to 10% (Phoenix Connector)

Housing

- Dimension : 8.26" x 11.41" x 9.05"
- Material : High Pressure Die-Cast Aluminum, Tempered Glass
- Weight : 15 lbs

Mounting

- Bracket

Warranty

- 5-year limited warranty

Listing

- ETL Damp Location Listed
- UKCA
- FCC
- CE
- IK10 (With Wire Guard)

PERFORMANCE SUMMARY*

Delivered Lumens					
CCT/WATTAGE	3000K	3500K	4000K	5000K	Royal Blue
100W	12,810lm	13,280lm	13,380lm	14,660lm	1,210lm

*Beam Angle: 60° *Tolerance ±8%

Current Consumption		
WATTAGE / VOLT	120V	277V
200W	1.83A	0.8A

PHOTOMETRICS

Below is a typical photometric representation of the Bolt Mini fixture. Please download IES files to ensure exact photometric value.

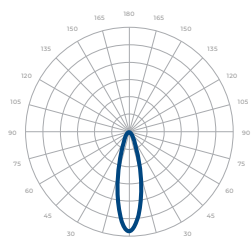

30°

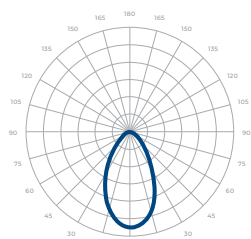

60°

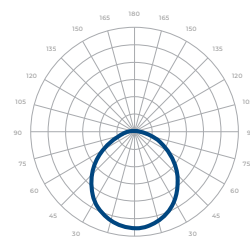

WIDE

DMX REQUIREMENTS

The Bolt Mini fixture with DMX is a **dual channel dmx** unit. When placing an order, please indicate DMX address. (The DMX address will be listed on the back of the fixture). Do not connect more than 32 fixtures per DMX daisy chain.

DMX Address		
Channel Fixture	White Control (ex. X)	Blue Control (ex. X+1)
#1	1	2
#2	3	4
#3	5	6

The fixture can be connected with XLR, RJ45 sockets or Phoenix Connector. DMX cables **are not** included; please refer to compatible DMX cabling list for more information. The final fixture on each daisy chain should be terminated by the use of a DMX terminator purchased from a 3rd party or from Meteor.

CONNECTION	RJ45 (CAT5e)	5-PIN XLR
Common	WHITE/BROWN(PIN7) & BROWN (PIN 8)	PIN 1
Signal -	ORANGE (PIN 2)	PIN 2
Signal +	WHITE/ORANGE (PIN 1)	PIN 3
Spare	-	PIN 4
Spare	-	PIN 5

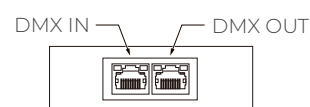

RJ45 Sockets



XLR Sockets

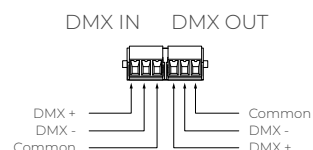

Phoenix Connector

COMPATIBLE DMX CABLING LIST

DMX uses a cable consisting of two twisted pairs plus a shield to carry data. The cable must be specifically impedance matched for the digital DMX signal, meaning that microphone cable or other non-rated cable **must not be used to carry DMX**. Network cable (Cat5, 5e or 6 cable) may be used to carry DMX in an installation; however special consideration must be given to shielding and termination. Under no circumstances should solid core cable like Cat5 be terminated into a screw down connector.

Meteor recommends the use of Belden 9729 or Belden 9841 for DMX installation. Belden 9729/9841 is a shielded twisted pair cable, which allows for a spare pair for 'out and back' type terminations if needed.

LED DISTRIBUTION

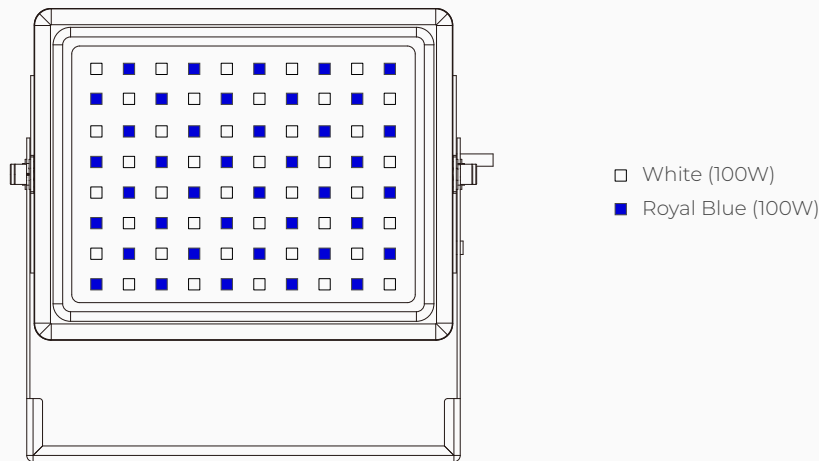

DIMENSIONS

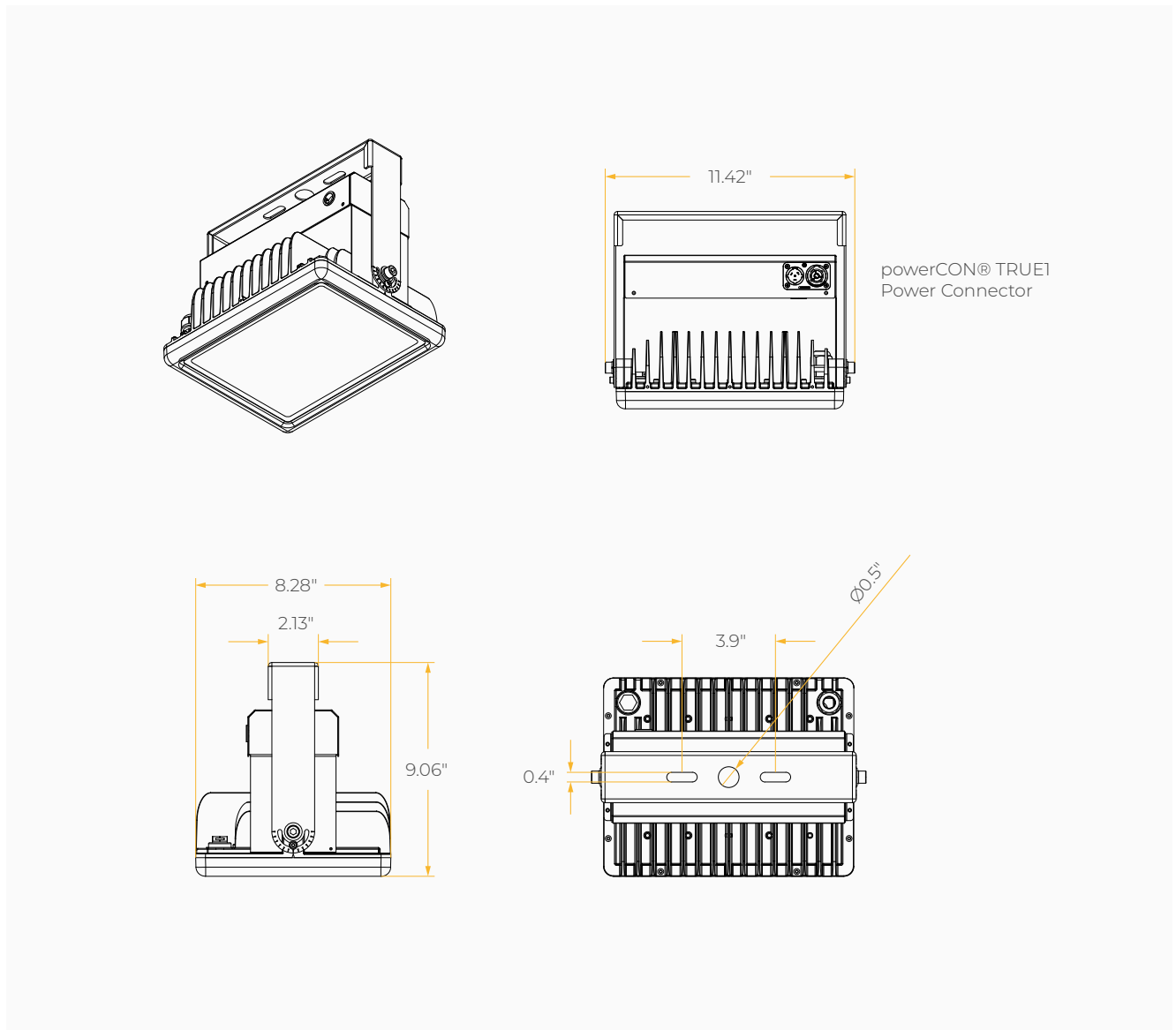

ACCESSORIES

Glare Shield Baffle

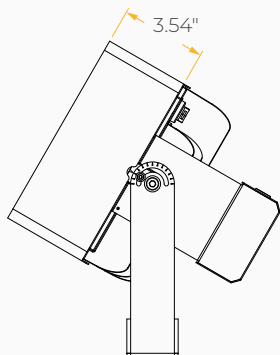

Glare Shield Visor

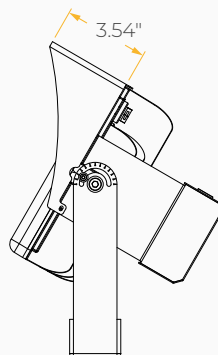

Wire Guard

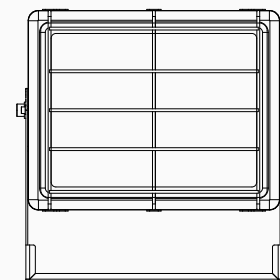

C-clamp Mount

